

Quicksilver Audio Horn Mono Amplifier

Operating Instructions

Thank you for purchasing the Quicksilver Audio Horn Monos. Simplicity and affordability are what these amplifiers are all about. Enjoy!

The Horn Mono Amp has very low distortion, very low gain (20 db lower than most amps) and a very low output impedance. All these features, plus the sound of tubes, combine to give the best possible performance from high efficiency speakers.

INITIAL TURN-ON

Insert the tubes in their proper sockets. It may be difficult to insert the EL34s the first time. Gently move them back and forth a few times in the socket until you feel the pins move into the socket; then push the tube down firmly into the socket. If the tube pins are not properly lined up in the socket before you push the tube in, you may bend the tube socket pins. Connect the amp into the system and turn it on. The amplifier is self-biasing so no adjustments are necessary. You should, however, be sure to use D.C. matched output tubes.

FUSE BLOWING

If the 1.5 amp (slo-blo) fuse blows, replace it with no larger than a 2 amp fuse. If the fuse continues to blow an output tube could be damaged; or there may be other problems, such as poor system grounding, an unstable preamp, a shorted speaker, etc. Interchanging the cables between channels can help determine if the problem is in the system or in the amp.

TROUBLE SHOOTING

If the sound from one amplifier is distorted and you suspect the amp, switch output tubes between amplifiers to determine if an output tube is bad.

TUBE REPLACEMENT

The Horn Mono is sold with matched EL34 output tubes; but KT88s, KT77s, KT66s, 6L6s and 6550s can also be used; however both output tubes must be the same type. Output tubes must be replaced as a matched pair and should be purchased through Quicksilver Audio or a Quicksilver dealer. Quicksilver output tubes are "burned-in" for 10 hours prior to matching, and their performance is guaranteed.

The small tube in the Horn Mono is a 12DW7 and should only be replaced with a 12DW7 or 7247. Other types should not be used.

SPECIAL FEATURES

The Quicksilver Horn Mono uses no circuit boards or transistors. It is hand-wired, uses gold-plated input and output connectors, and has a very high performance output transformer.

Horn Mono Amp:

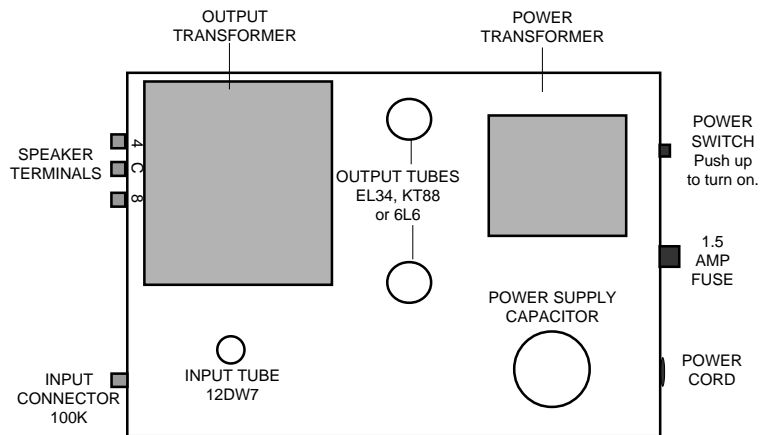
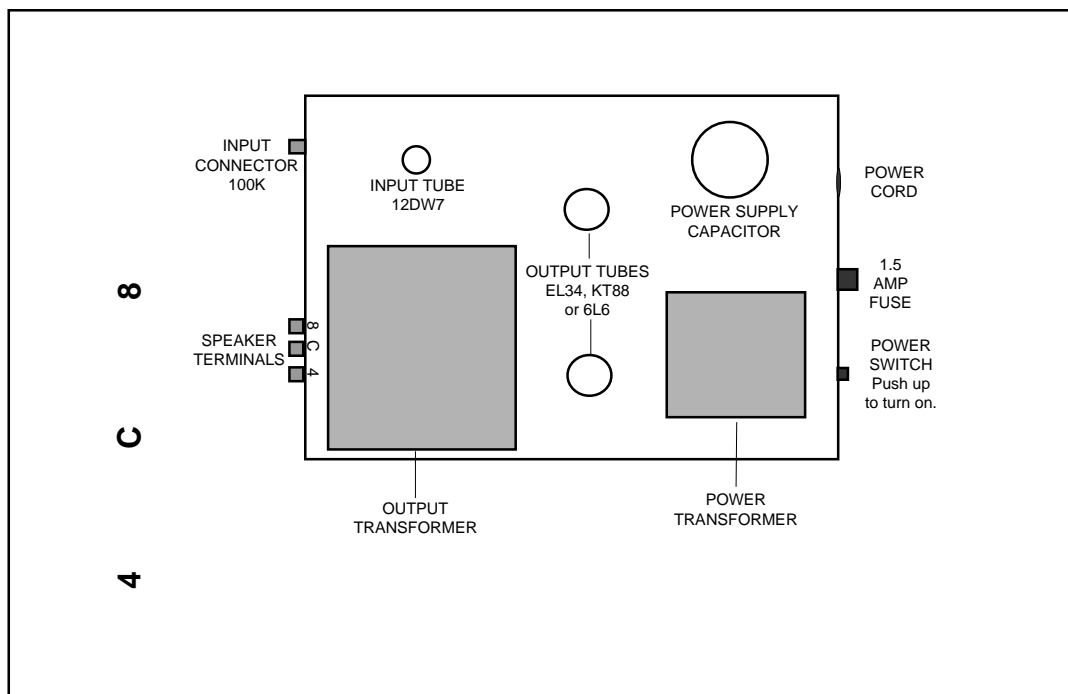

DIAGRAM ON THE BOTTOM OF THE AMPLIFIER:



Specifications

Power Output	25 watts into 4 or 8 ohms
Power Bandwidth	9 Hz to 100 KHz
Peak Power	50 watts
Input Sensitivity	9 volts
IM Distortion	less than 0.02% at 1 watt or less
Tube Complement	two EL34s, one 12DW7
Chassis	Chrome over nickel
Dimensions	8" x 14 3/4" x 9 1/4"
Weight	30 lbs. each
U.S. Warranty	3 years

WARRANTY

Quicksilver Audio warranties your new amplifiers for a period of three years from the date of purchase (90 days on tubes.) Parts and labor are provided free of charge as long as the failure was not caused by misuse, accident or negligence. Shipping to the factory is not included. Retain your packing carton in case the unit needs to be returned for service.

Quicksilver Audio
5635 Riggins Court, Unit 15
Reno, NV 89502
(775) 825-1514 / Fax 825-1552
www.quicksilveraudio.com